

CAR 400

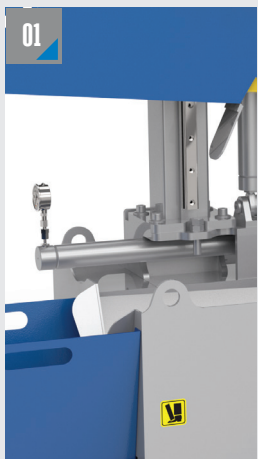

TAM OTOMATİK HİDROLİK SÜTUNLU TESTERE TEZGAHI FULL AUTOMATIC DOUBLE COLUMN HYDRAULIC BANDSAW MACHINE



MALZEME SIKMA SİSTEMİ
MATERIAL CLAMPING SYSTEM



HAREKET SİSTEMİ
LINEAR GUIDING



ŞERİT GERDİRME SİSTEMİ
BLADE TENSIONING



MALZEME SÜRME SİSTEMİ
MATERIAL FEEDING SYSTEM





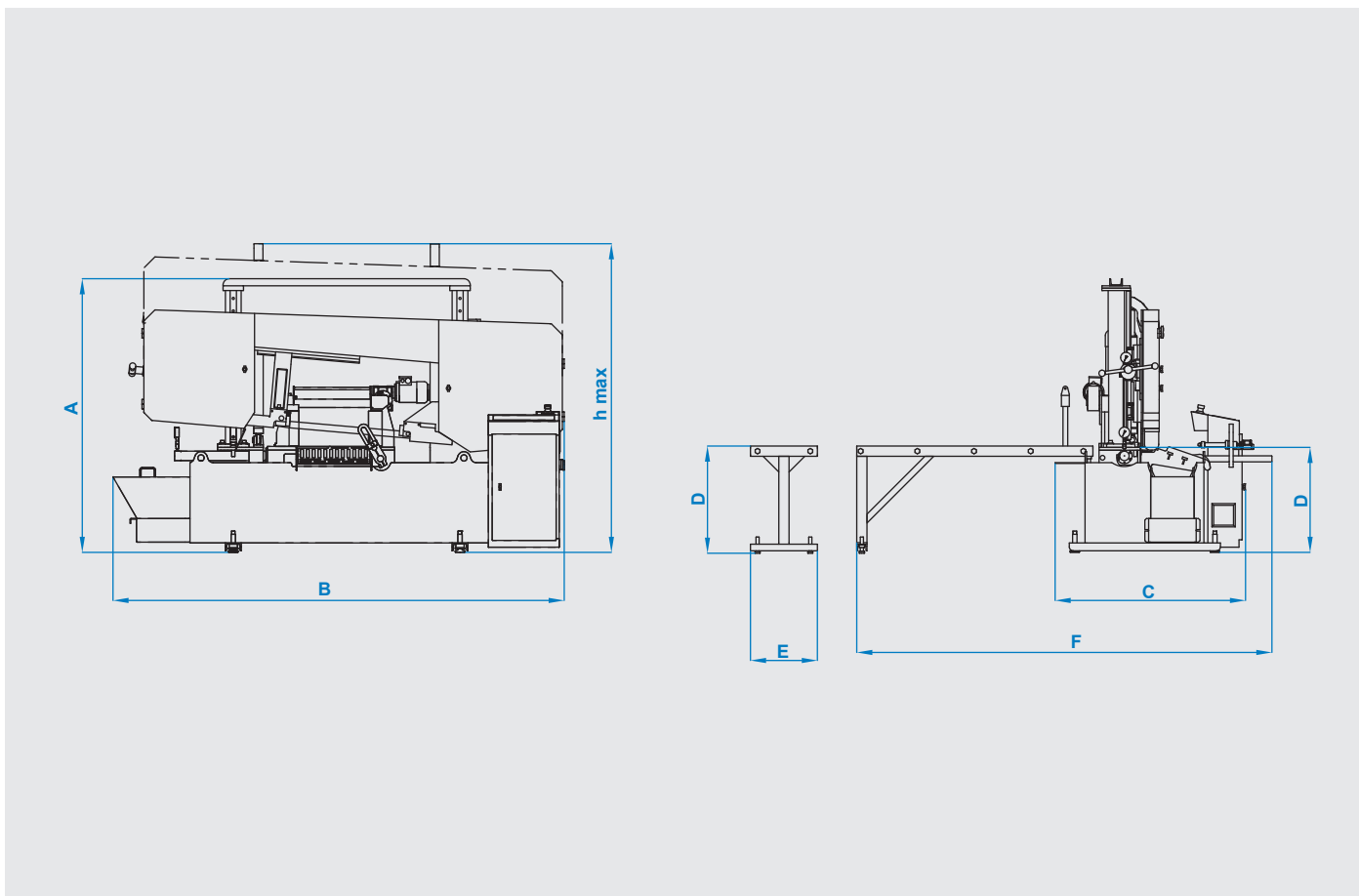



ÖLÇÜLER DIMENSIONS



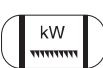
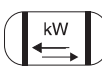
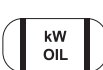
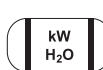





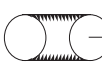

SÜTUNLU MODELLER DOUBLE COLUMN TYPES



TEKNİK ÖZELLİKLER / TECHNICAL FEATURES

A	1740 mm 68.50 inch	B	2870 mm 112.99 inch	C	1376 mm 54.17 inch	D	670 mm 26.38 inch	E	425 mm 16.73 inch	F	2640 mm 103.94 inch	hmax	1965 mm 77.36 inch
---	-----------------------	---	------------------------	---	-----------------------	---	----------------------	---	----------------------	---	------------------------	------	-----------------------

 Otomatik Automatic	 Şerit Ölçüsü Blade Dimension 41 x 1.3 x 5715 mm 1 1/2 x 0.050 x 225 inch	 kW Şerit Motoru Blade Motor 4 kW - 1000 d/d 5.36 hp - 1000 rpm	 kW Sürücü Motor Feeding Motor 0.37 kW - 925 d/d 0.49 hp 925 rpm
 kW OIL Hidrolik Motor Hydraulic Pump Motor 0.75 kW - 1500 d/dk 1 hp - 1500 rpm	 kW H ₂ O Soğutucu Motor Cooling Liquid Motor 0.12 kW - 3000 d/dk 0.16 hp - 3000 rpm	 Voltaj Voltage 400 V 400 V	 Maksimum Güç Maximum Power 5.24 kW 7.03 hp
 Kesme Hızı Cutting Speed 15 m/dk - 49 m/dk 100 m/dk - 328 ft/min	 KG LBS Ağırlık Weight 1250 kg 2755 lbs	 Malzeme Sıkma Sistemi Material Clamping System Hidrolik Hydraulic	 Şerit Germe Sistemi Blade Tensioning System Hidromekanik Hydramechanic

 Kesim Kapasitesi Cutting Capacity	 Kesim Kapasitesi Cutting Capacity	 mm inch	 60°	 45°	 30°	 0°	 90°	 45°	 60°
400 mm 15.75 inch	550 mm 21.65 inch	● ■ ■				400 mm 15.75 inch 400 x 400 mm 15.75 x 15.75 inch 400 x 550 mm 15.75 x 21.65 inch			