

PSM 220 / 330 DM

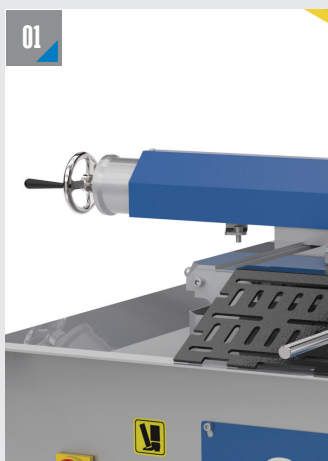

YARI OTOMATİK ÇİFT YÖN AÇILI TESTERE TEZGAHI SEMI AUTOMATIC DOUBLE MITER BANDSAW MACHINE



MALZEME SIKMA SİSTEMİ
MATERIAL CLAMPING SYSTEM



MALZEME DAYAMA MİLİ
MATERIAL STOP SPINDLE



KUMANDA PANELİ
CONTROL PANEL



AÇILI KESİM
MITER CUTTING

ÖLÇÜLER DIMENSIONS

MAFSALLI MODELLER PIVOT TYPES

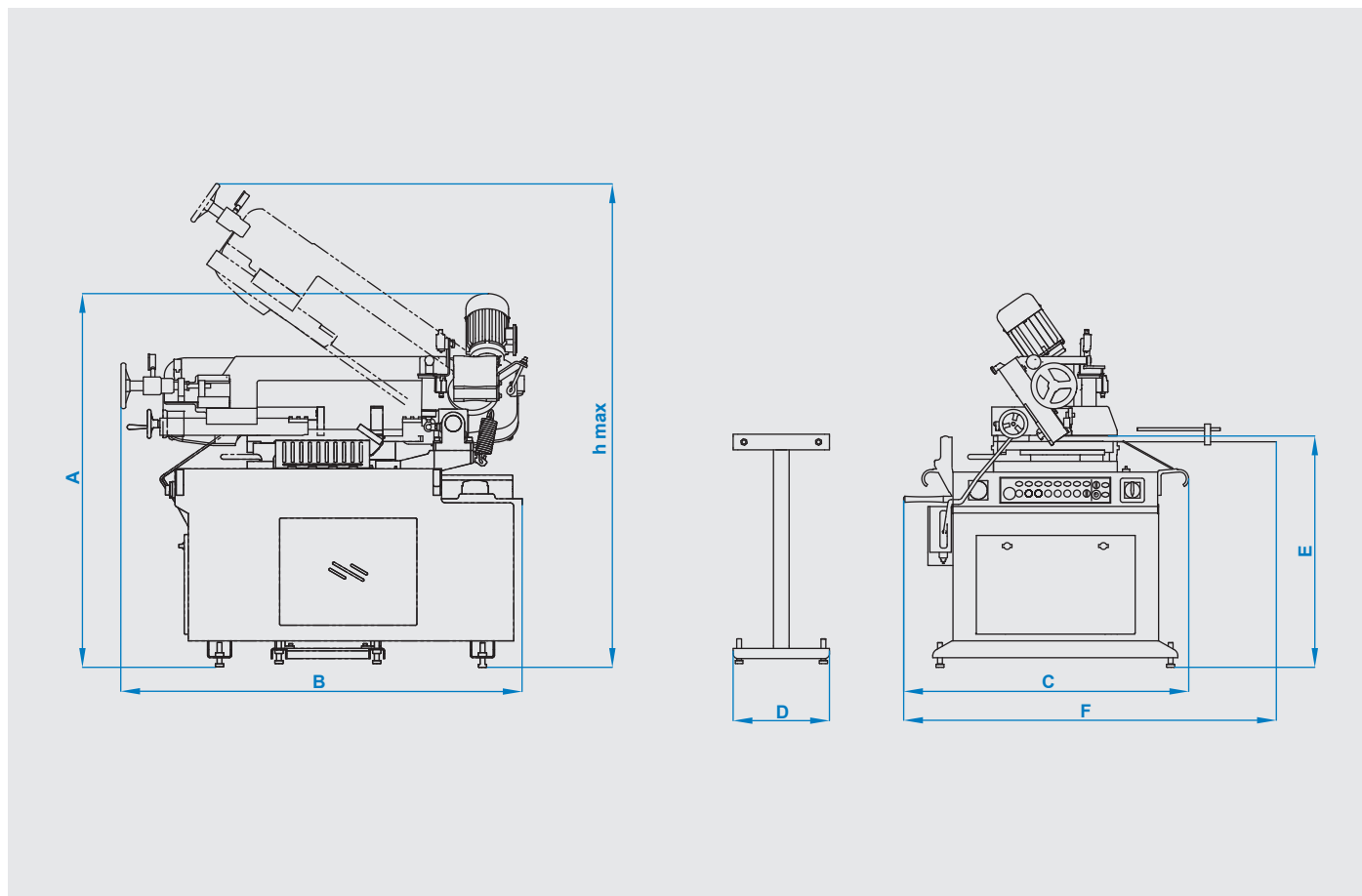

TEKNİK ÖZELLİKLER / TECHNICAL FEATURES

A	1555 mm 61.22 inch	B	1670 mm 65.75 inch	C	1185 mm 46.65 inch	D	400 mm 15.75 inch	E	695 mm 27.36 inch	F	455 mm 17.91 inch	hmax	2010 mm 79.13 inch
---	-----------------------	---	-----------------------	---	-----------------------	---	----------------------	---	----------------------	---	----------------------	------	-----------------------

Yarı Otomatik Semi Automatic	Şerit Ölçüsü Blade Dimension 27 x 0.9 x 3175 mm 1 x 0.035 x 125 inch	Şerit Motoru Blade Motor 1.1 kW - 1000 d/d 1.47 hp - 1000 rpm	Sürücü Motor Feeding Motor Manuel Manual
Hidrolik Motor Hydraulic Pump Motor 0.75 kW - 1400 d/dk 1 hp - 1400 rpm	Soğutucu Motor Cooling Liquid Motor 0.12 kW - 3000 d/dk 0.16 hp - 3000 rpm	Voltaj Voltage 400 V 400 V	Maksimum Güç Maximum Power 1.97 kW 2.64 hp
Kesme Hızı Cutting Speed 25 m/dk - 100 m/dk 82 m/dk - 328 ft/min	Ağırlık Weight 670 kg 1477 lbs	Malzeme Sıkma Sistemi Material Clamping System Pnömatik Pneumatic	Şerit Germe Sistemi Blade Tensioning System Hidromekanik Hydramechanic

Kesim Kapasitesi Cutting Capacity	Kesim Kapasitesi Cutting Capacity	mm inch	60°	45°	30°	0°	30°	45°	60°
220 mm 8.66 inch	330 mm 12.99 inch		220 mm 8.66 inch	220 mm 8.66 inch	220 mm 8.66 inch	220 mm 8.66 inch	220 mm 8.66 inch	220 mm 8.66 inch	130 mm 5.11 inch
			180 mm 7.08 inch	220 mm 8.66 inch	220 mm 8.66 inch	220 mm 8.66 inch	220 mm 8.66 inch	210 mm 8.26 inch	110 mm 4.33 inch
			220 x 180 mm 8.66 x 7.08 inch	220 x 280 mm 8.66 x 11.06 inch	220 x 330 mm 8.66 x 12.99 inch	220 x 280 mm 8.66 x 11.06 inch	210 x 180 mm 8.26 x 7.08 inch	100 x 130 mm 3.93 x 5.11 inch	